

New Products

CONTACT No. 309

NKK
SWITCHES
Innovation Driving Quality

Series TP01

Operates at a Gentle Touch

Enables smooth multi-touch operations on a resistive film touch screen



4-Wire Analog Touch Screens

NKK SWITCHES CO., LTD.

Enables Input with a Gentle Touch on an Analog Resistive Film Touch Screen

Combine with an Optional Control Board to
Enable Multi-touch Functions

Input by Two-Point Gestures Allows Easy Input through Gentle Touch

The input pressure is half that of our previous products, enabling reliable input and easy operations. **A dedicated control board can be used to enable multi-touch operations such as pinching in and out.**

Wide Variety of Compatible Screen Sizes

Analog: 10.4", 10.6" (Wide),
12.1", 12.1" (Wide),
15", 15.6" (Wide),
19"

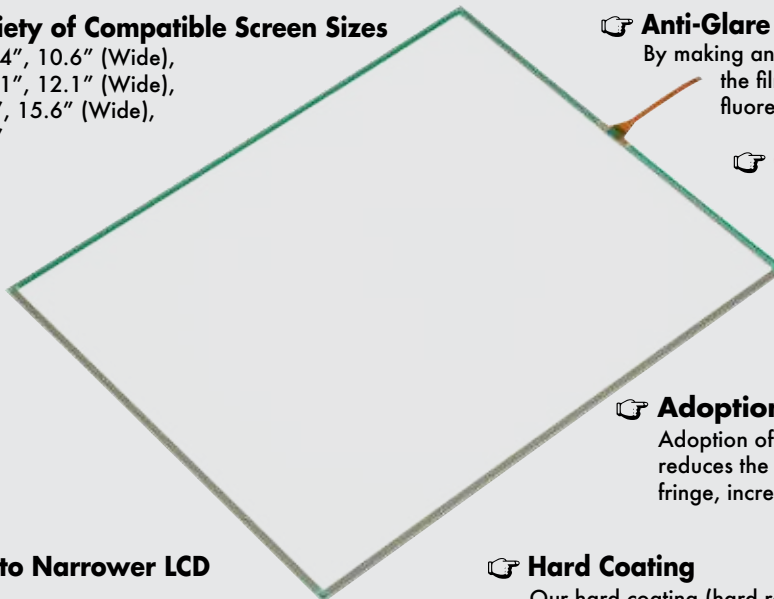

Standard Product (Film + Glass)

Wide Range of Input Methods

Our resistive film touch screens allow all kinds of input methods. Input is possible by finger or pen – even when wearing gloves.

Anti-Glare Surface Treatment

By making anti-glare surface treatment toward the film surface, we made reflection of fluorescence soft.

Contains Metal Tail

A metal tail is now included as a standard feature.

Adoption of ANR Film

Adoption of ANR (Anti Newton-Ring) film reduces the occurrence of interference fringe, increasing visibility. of the screen.

Catering to Narrower LCD Frames

We've made the frames of our touch screens narrower so that they do not interfere with the design of narrow-framed LCDs. (All sizes except 10.6" can be made with a narrow frame.)

Adoption of Resistive Film Mode

The TP01 series are resistive film touch screens that take full advantage of transparent conductive thin film technology. Incorporating these films into a wide variety of display equipment such as LCD screens and plasma EL enables simple, interactive input operation even for people who do not have specialist technical or computer knowledge.

Touch screens are currently used in a wide variety of applications. Resistive films represent a high degree of freedom for input methods (digital, analog), size, and design with for a relatively low cost.

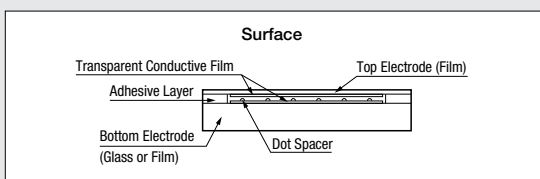

Hard Coating

Our hard coating (hard resin coating) provides superb protection to the surface of the films against scratches and damage from fingers and pens.

Controller Boards

Combining an analog touch screen with a controller board device driver on a computer enables you to perform the same operations as you would with a mouse simply by touching the touch screen.

Flexible Compatibility for a Wide Range of Requirements.

Customized Products (Resistive film method)

The size of resistive film products can be **adjusted according to your needs**, even down to palm-sized products.

Can be incorporated into peripheral devices or **attached to LCDs**.

The **material composition can be adjusted according to use**, such as film + film.

A wide range of films such as fingerprint-resistant and high transmittance films are also **available**.

Input methods such as pen input or finger input can also **be specified**.

► General Specifications

4-Wire Analog Touch Screens		
Power level	1 mA 5.5 V DC (Resistive load)	
XY Resistive Value	250–850 Ω (Wide type: 120–1,500 Ω)	
Linearity	±1.5% maximum	
Insulation Resistance	10 MΩ minimum @ 25V DC	
Expected Operating Life	Writing	50,000 maximum operations (approximately 30 mm movement with stylus)
	Tapping	1,000,000 operations minimums (using 60° silicone rubber)
Touch Activation Force	0.02–1 N maximum	
Chattering Time	10 milliseconds maximum	
Relative Humidity	+40 °C, 90% relative humidity, 240 hours (no condensation)	
Operating Temperature Range	-20 – +70 °C	
Storage Temperature Range	-40–+80 °C	
Light Transmission	80% (TYP.) (Touch screen section)	
Surface Hardness	3H or harder (JIS K5400) (Pencil hardness)	

Each rated value/performance value is obtained through independent testing. Therefore, the same results are not guaranteed under complex conditions. Please refer to General Specifications page in General Catalog "Switch Guide" on specific models, ratings and ordering instructions.

► Applications

•FA Systems

Production process management systems, production system control, input systems for various manufacturing equipment, plant control systems

•Communication Systems

Reception guidance systems, restaurant automation systems, POS systems, traffic systems

•OA Systems

Various OA devices for input systems, building management systems, business administration systems, schedule management systems

•Medical System

Medical chart management systems, medical data processing systems, physical treatment systems, bedside monitors

•Measuring Instruments

► Typical Ordering Example

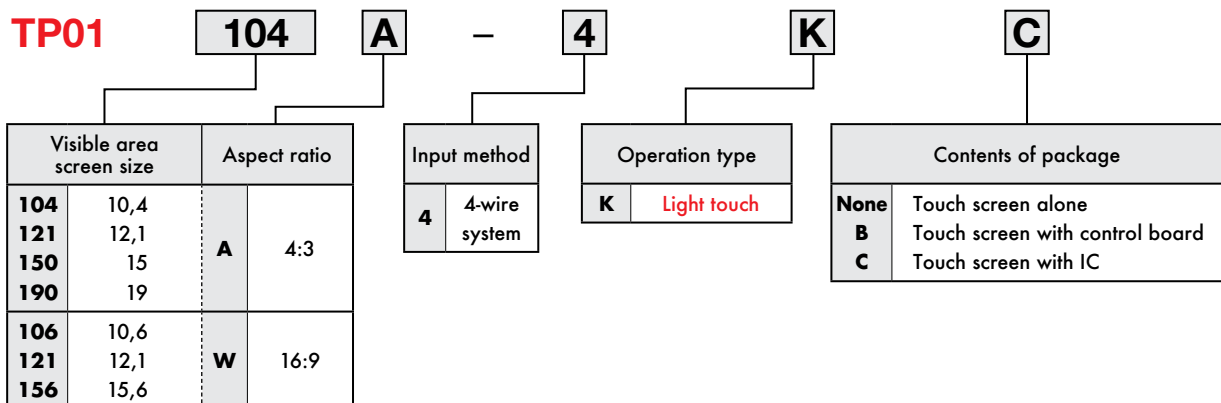

► Part Numbers & Descriptions

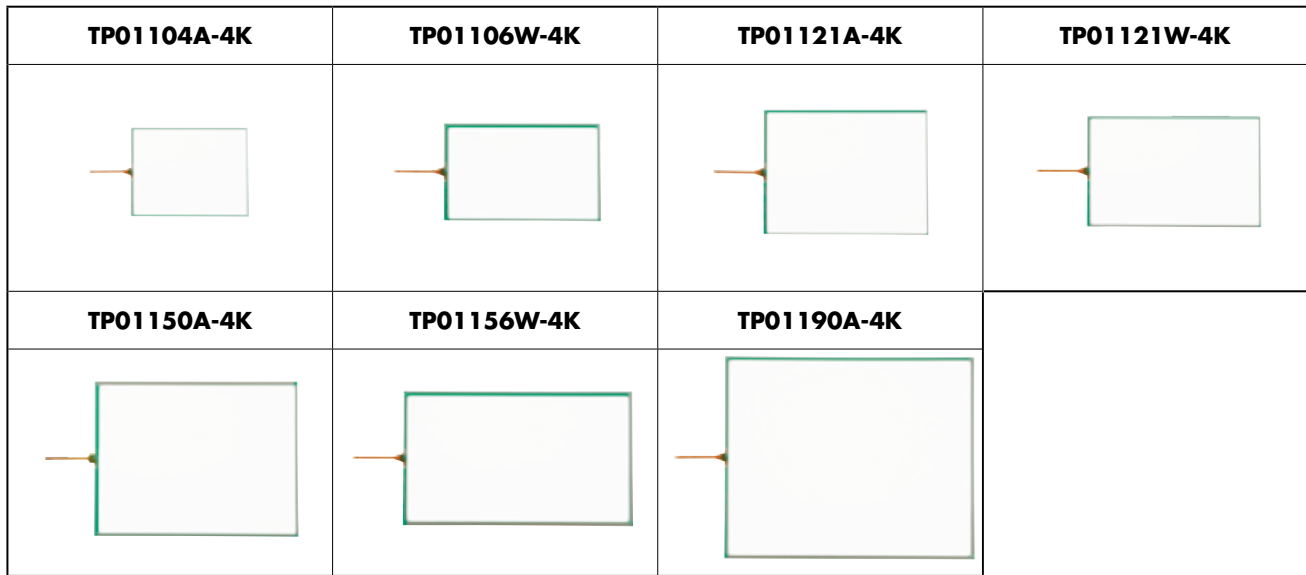

Part Number	Screen Size in Inches	Input Methods	Key Area Dimensions (mm)	Viewing Area Dimensions (mm)	External Dimensions (mm)	Screen Thickness (mm)	Terminal Detail
TP01104A-4K	10.4	Finger or pen	211.2×158.4	215×162.4	225.6×171.4	2.1	1 mm pitch 4 pin Length 80 mm
TP01106W-4K	10.6W	Finger or pen	230.4×138.2	233.4×141.3	247.8×154.8	2.1	1 mm pitch 4 pin Length 80 mm
TP01121A-4K	12.1	Finger or pen	245.8×184.3	249.6×188.1	260×198	2.1	1 mm pitch 4 pin Length 80 mm
TP01121W-4K	12.1W	Finger or pen	261.12×163.2	264.26×166.4	275×176	2.1	1 mm pitch 4 pin Length 80 mm
TP01150A-4K	15	Finger or pen	304.1×228.1	308.1×232.1	321.8×245.5	2.1	1 mm pitch 4 pin Length 77.7 mm
TP01156W-4K	15.6W	Finger or pen	344.2×193.5	347.5×196.8	362.6×214.2	2.1	1 mm pitch 4 pin Length 80 mm
TP01190A-4K	19	Finger or pen	376.3×301	382×307.4	395.5×321	2.1	1 mm pitch 4 pin Length 80 mm

► Sales Start Date

June 12 , 2017

► General Specifications

TP01104A-4K

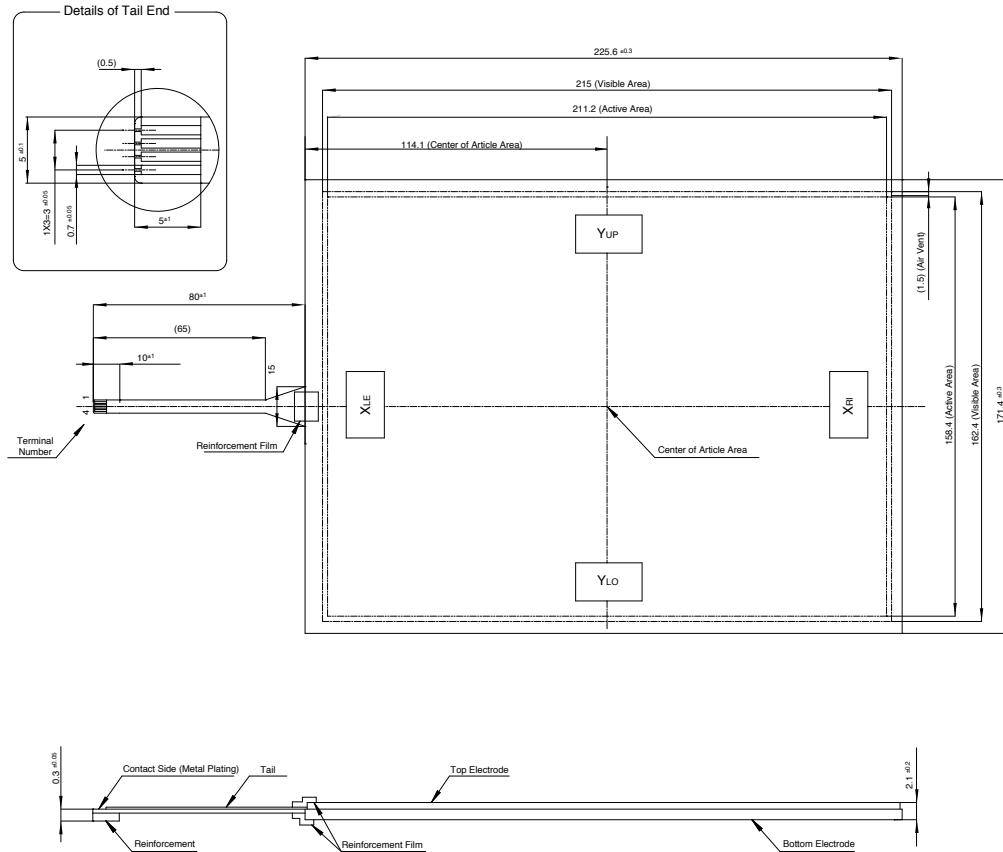

Specifying circuit

Pins	Signal
1	Y _{UP}
2	Y _{LO}
3	X _{LE}
4	X _{RI}

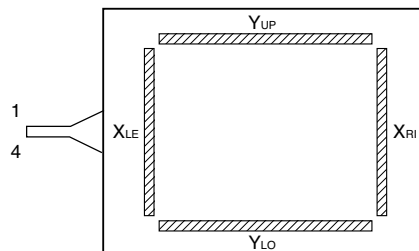

Y_{UP}, Y_{LO} : Bottom Electrode Contact
 X_{LE}, X_{RI} : Top Electrode Contact

TP01106W-4K

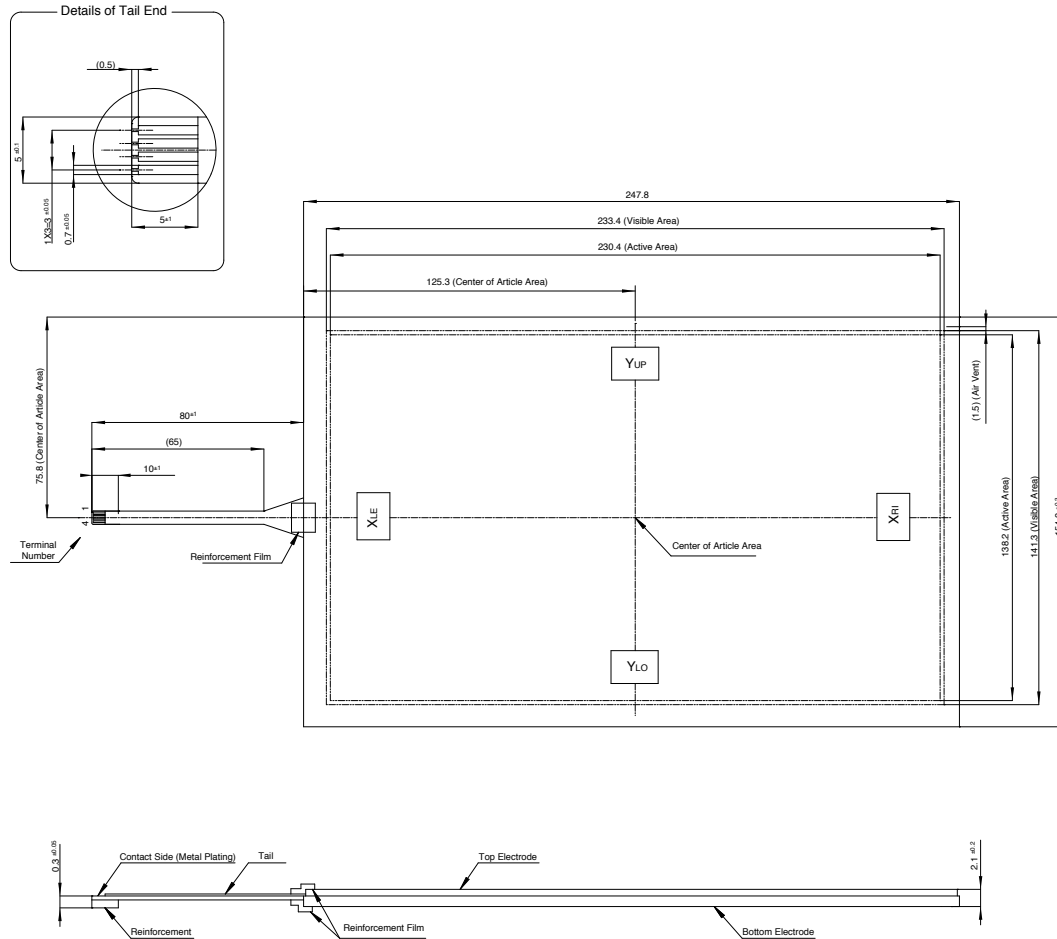

Specifying circuit

Pins	Signal
1	Y _{UP}
2	Y _{LO}
3	X _{LE}
4	X _{RI}

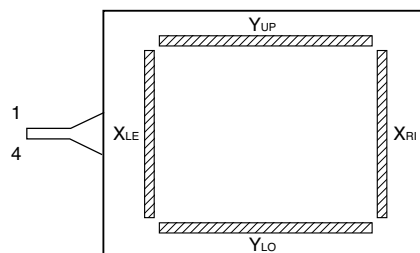

Y_{UP}, Y_{LO} : Bottom Electrode Contact
 X_{LE}, X_{RI} : Top Electrode Contact

TP01121A-4K

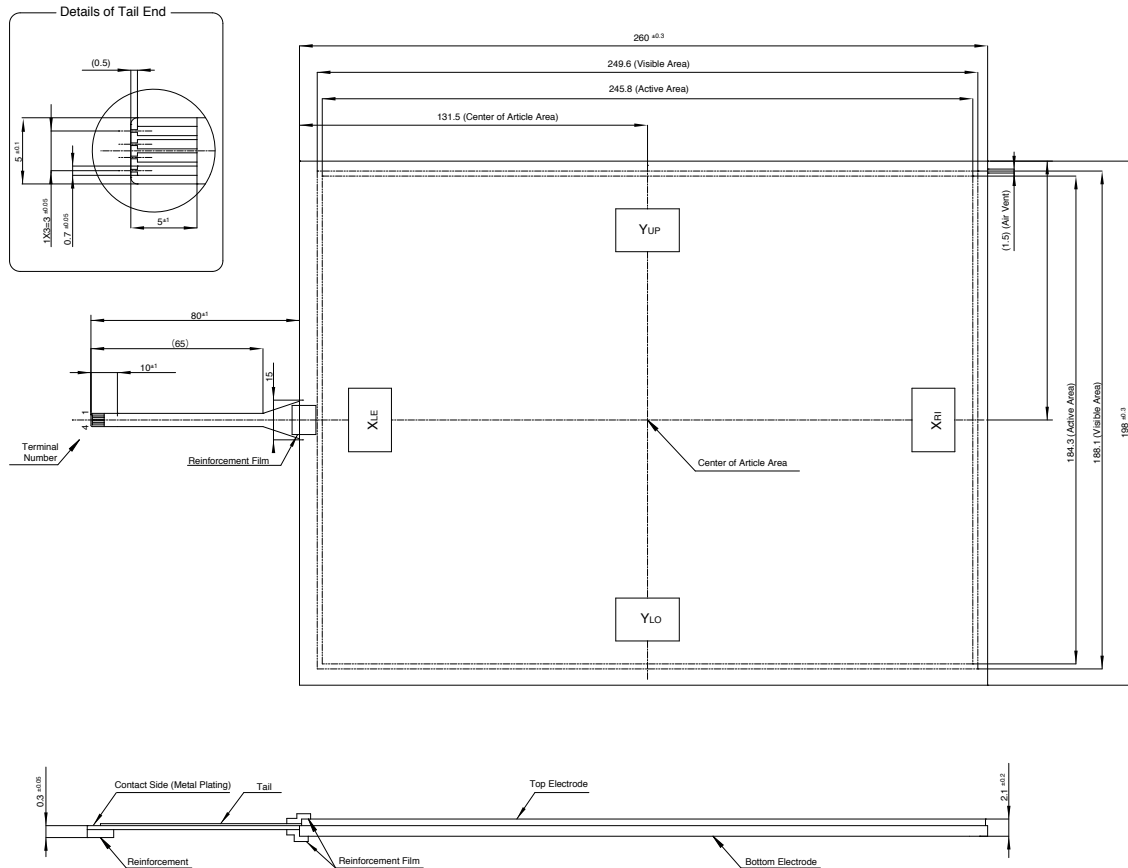

Specifying circuit

Pins	Signal
1	Y _{UP}
2	Y _{LO}
3	X _{LE}
4	X _{RI}

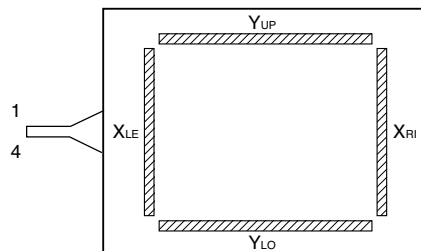

Y_{UP}, Y_{LO} : Bottom Electrode Contact
 X_{LE}, X_{RI} : Top Electrode Contact

TP01121W-4K

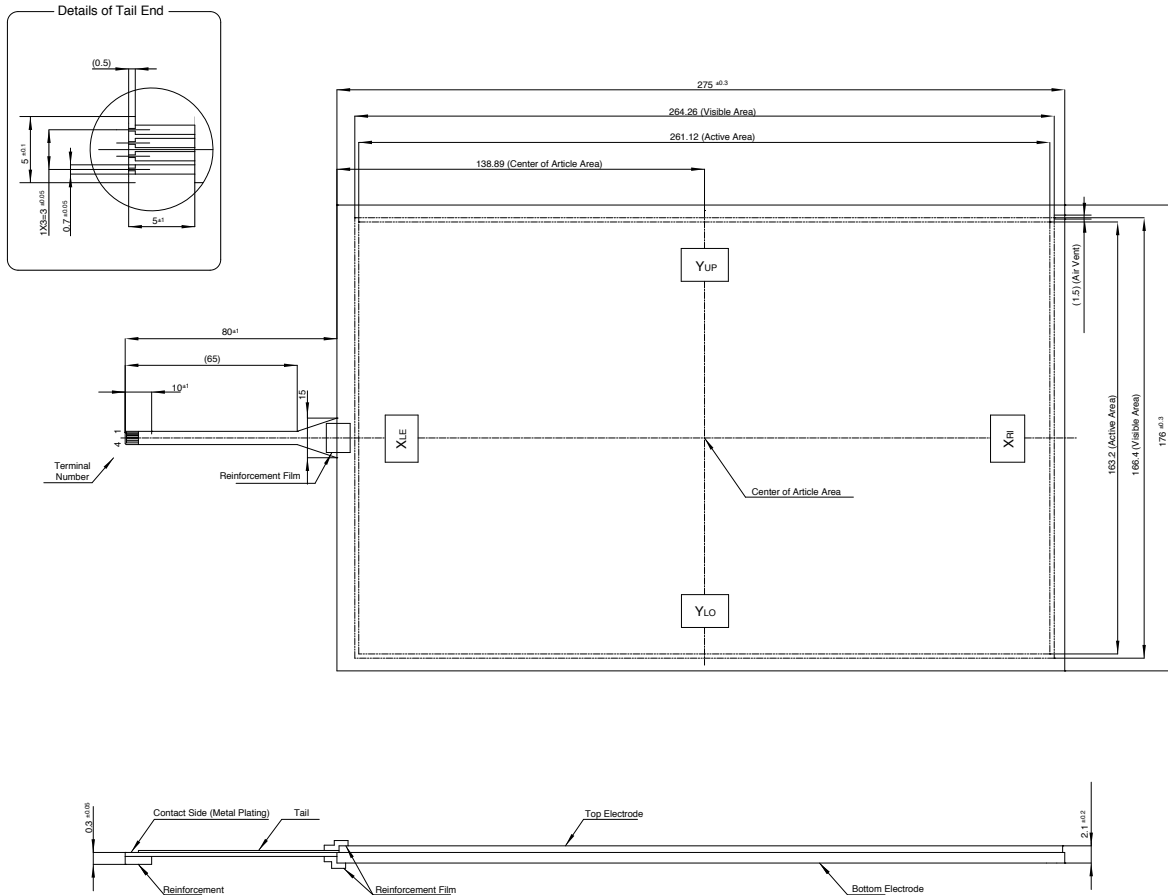

Specifying circuit

Pins	Signal
1	Y _{UP}
2	Y _{LO}
3	X _{LE}
4	X _{RI}

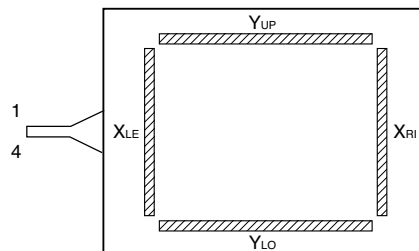

Y_{UP}, Y_{LO} : Bottom Electrode Contact
 X_{LE}, X_{RI} : Top Electrode Contact

TP01150A-4K

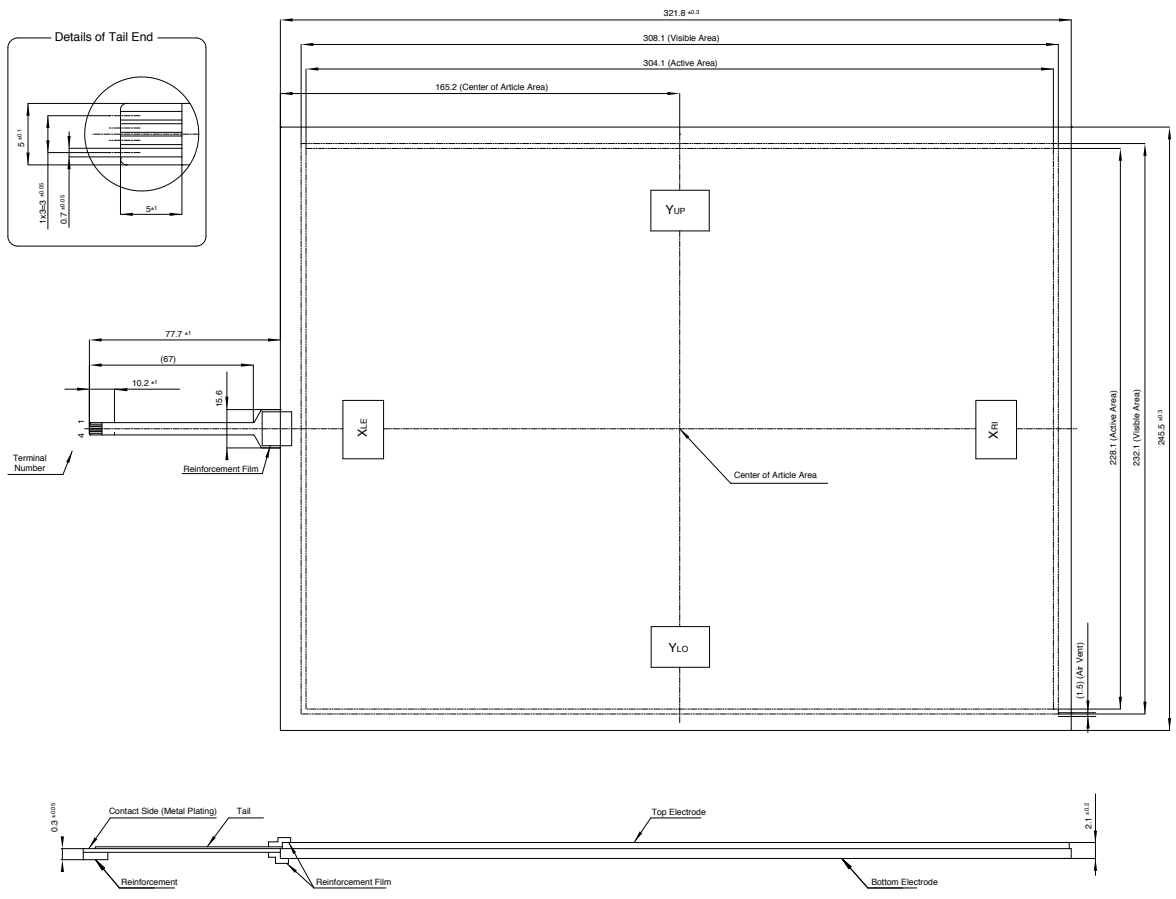

Specifying circuit

Pins	Signal
1	Y _{UP}
2	Y _{LO}
3	X _{LE}
4	X _{RI}

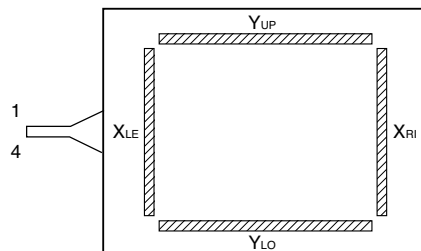

Y_{UP}, Y_{LO} : Bottom Electrode Contact
 X_{LE}, X_{RI} : Top Electrode Contact

TP01156W-4K

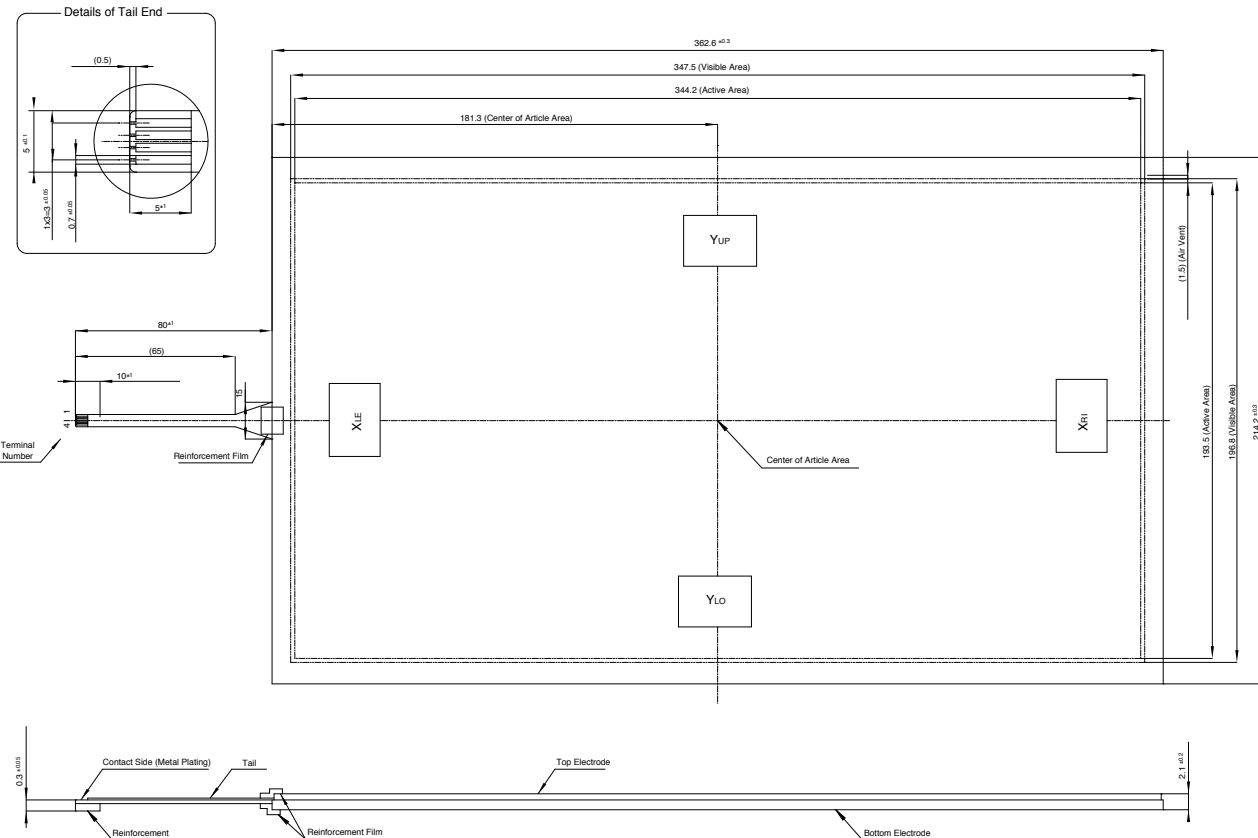

Specifying circuit

Pins	Signal
1	Y _{UP}
2	Y _{LO}
3	X _{LE}
4	X _{RI}

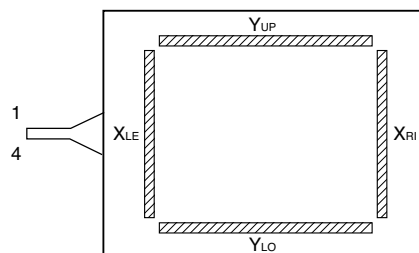

Y_{UP}, Y_{LO} : Bottom Electrode Contact
 X_{LE}, X_{RI} : Top Electrode Contact

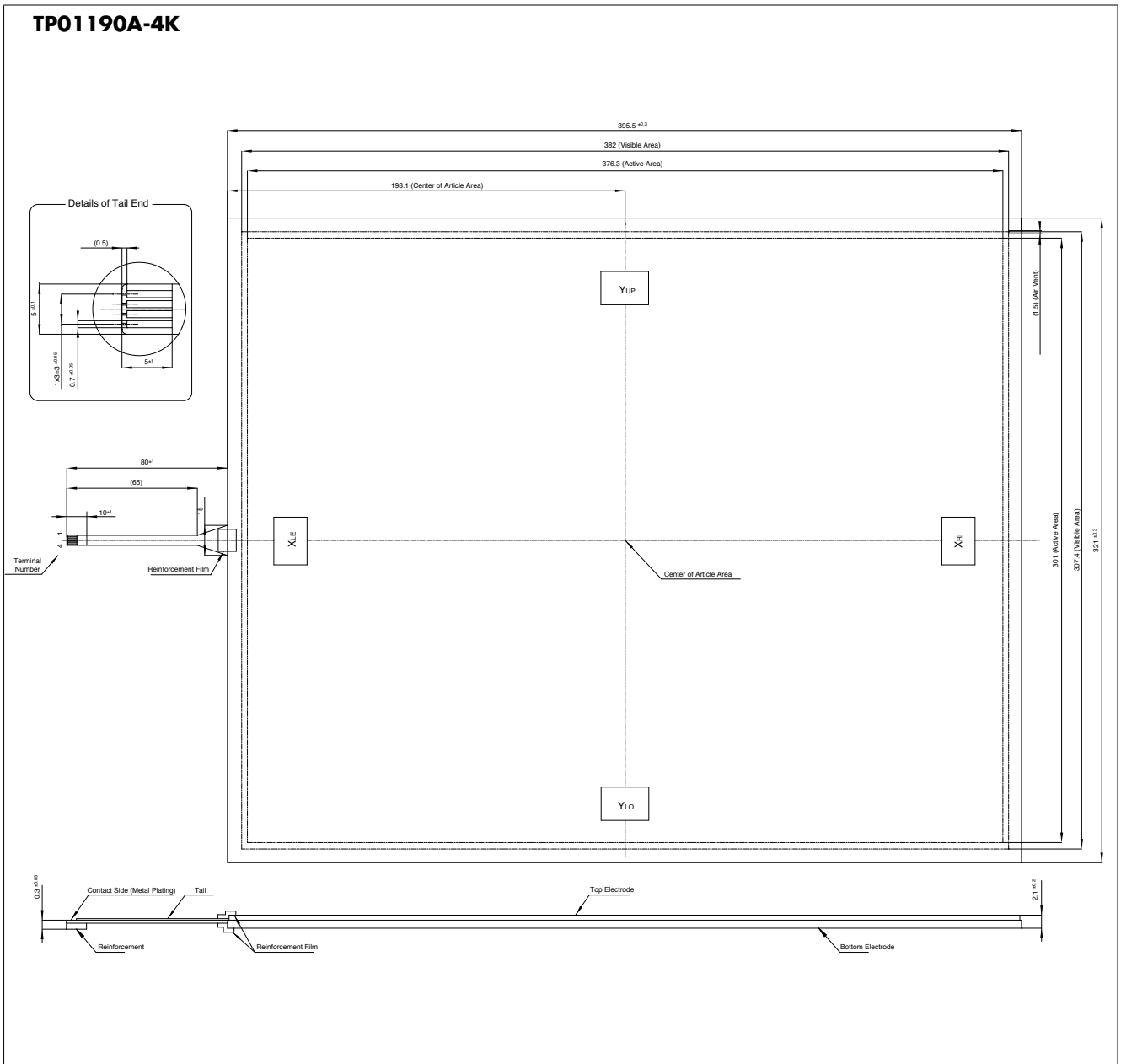

Specifying circuit

Pins	Signal
1	Y _{UP}
2	Y _{LO}
3	X _{LE}
4	X _{RI}

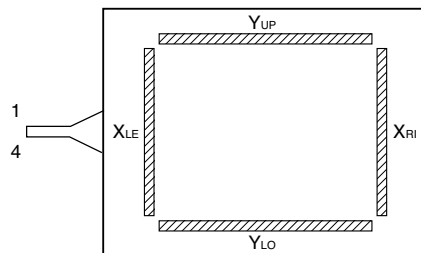

Y_{UP}, Y_{LO} : Bottom Electrode Contact
 X_{LE}, X_{RI} : Top Electrode Contact

▶ Controller Board

Unlimited Interfaces that Expand at A Touch

- Compatible with USB interface
- Device drivers are Windows 7, 8 and 10 compatible

System Configuration (for USB compatible system)

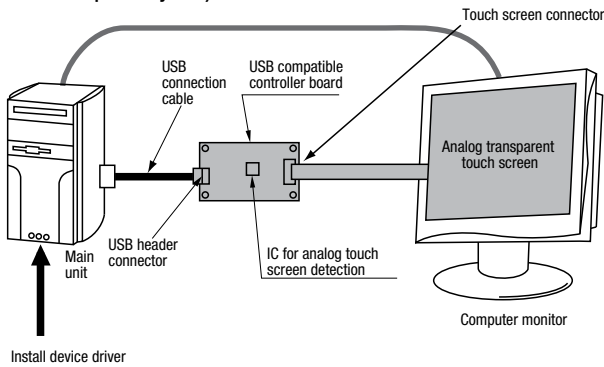

■ are products handled by NKK Switches Co., Ltd.

Combining an analog touch screen with a controller board device driver on a computer enables you to perform the same operations as you would with a mouse simply by touching the touch screen.

Controller Board		
Model	Interface	Type
TP01**-4KB	USB	4-wire system

Insert 104A, 106W, 121A, 121W, 150A, 156W or 190A in the position indicated by "***".

All touch screen sets include the TP01 series control board and detection IC.

Maximum Rating				
Items	Symbols	Rated value		Unit
		Min	Max	
Supply voltage	V_{CC}	+4.5	+5.5	[V]
Input voltage	V_{TP}	—	V_{CC}	[V]
Operating temperature	T_{OPR}	-20	+70	[°C]
Storage temperature	T_{STG}	-30	+85	[°C]

Recommended Operation Conditions						
Items	Symbols	Rated value			Unit	Notes
		Min	Typ	Max		
Supply voltage	V_{CC}	+4.5	+5	+5.5	[V]	
Operating temperature	T_{OPR}	-20	—	+70	[°C]	No condensation

► Control Board

- Combining an analog touch screen with a control board device driver on a computer enables you to perform the same operations as you would with a mouse simply by touching the touch screen. Supports multi-touch and allows gesture-based operations.
- Compatible OS: Windows 7/8/10

*Please review the product specifications before using control board. Please contact our sales department for product specifications.

► IC for Analog Touch Screen Detection

- This IC performs high-speed, high accuracy coordinate conversion for the touch position of analog touch screens. The analog voltage detected from the touch screen is converted to A/D, and the coordinate value is output via serial data (start-stop synchronization) or USB.
- Supports multi-touch and allows gesture-based operations.
- Compatible OS: Windows 7/8/10

*Please review the product specifications before using IC. Please contact our sales department for product specifications.

Features

- High speed, high accuracy
- Built-in noise reduction function for input coordinate data (reduction of bounce, external device noise, etc.)
- Built-in calibration function

► Position Correction Software

- Position correction software is provided for use with control boards and IC.
- Compatible OS: Windows 7

► USB Compatible Controller Board

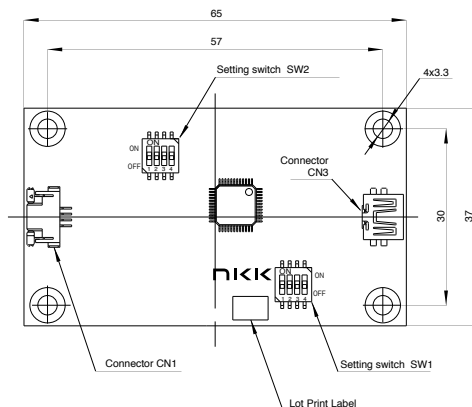

Direction of Tail Insertion

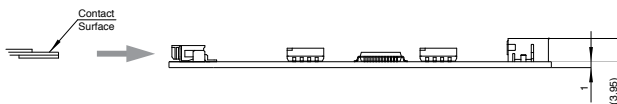

CN1

For connecting to 4-wire system analog touch screen (8-pin)

Pins	Symbol	Terminals
1	Y _{UP}	Panel driving terminal PSW2
2	Y _{Lo}	Panel driving terminal PSW1, PSW5
3	X _{LE}	Panel driving terminal PSW4
4	X _{RI}	Panel driving terminal PSW3, PSW6

CN3

Header connector for USB (5-pin)

Pins	Symbol	Terminals
1	V _{CC}	V _{CC}
2	D ₋	D ₋
3	D ₊	D ₊
4	GND	V _{SS} (0 V)
5	FG	Shield GND

► Instructions

Controller Board Handling Precautions

- This product is not guaranteed to operate when combined with a touch screen manufactured by any company other than NKK Switches.
- Be careful of static electricity when handling this product, and ensure workers and working areas where this product is handled are earthed.
- Do not turn on the power supply to this product until it is connected to both the host and touch screen.
- When connecting or disconnecting the CN1 connector of this product and touch screen tail section, be sure that the CN1 connector slider is pulled back, and refrain from connecting or disconnecting more than 10 times.
- Never attempt to modify this product.
- The content of this product may be changed at the manufacturer's discretion without prior notification for improvement purposes.
- Do not use commands other than those prescribed in the specifications with this product.
- NKK Switches cannot accept any responsibility whatsoever for any damages that occur through the use of this product.
- The tail used to connect the touch screen unit and controller board is susceptible to noise, and should therefore be installed as far away as possible from noise sources (LCD drive inverter, etc.).
- This product is covered under warranty for 1 year from the date of purchase.

Precautions for installation

- Make sure that the case or housing do not place unnecessary stress on the product causing it to distort.
- The tail section is the weakest part of the product and may disconnect easily. Therefore, do not pull on or place stress on the tail section.
- Do not place excessive stress (sufficient to leave a bend line) on the tail section. Doing so may cause disconnection or increased resistance value.
- When installing glass products in particular, be sure to consider vibration and impact during installation.
- Install the touch screen securely so there is no looseness. Looseness may cause detection to become unstable. In particular, looseness has an adverse effect on detection performance of analog types during operation.
- Make sure there is no burring, etc. at the edges of the case and housing. Burring may cause misoperation. Furthermore, ensure that the edges of the case and housing do not enter the key area. Doing so may cause misoperation due to the edges of the case or housing.
- Leave a space (approx. 0.5 mm) between the case or housing and top electrode to ensure there is no differential shrinkage in the case, housing or top electrode, and no effects from distortion or deformation. When installing buffer material in the space, make sure that the top electrode is not forcibly pushed. Forcibly pushing the top electrode or fixing with double-sided tape, etc., may cause the top electrode to distort or flex, which has an adverse effect on the external appearance and functionality of the product. Install buffer material more than 0.6 mm to the inside of the A section.

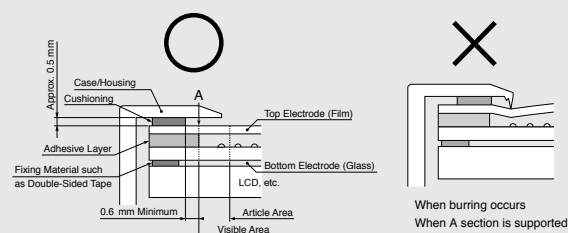

- In cases where external pressure may be placed on the periphery during operation such as the case or housing section being held by hand, make sure that the touch screen is not input due to distortion of the edges of the case or housing.
- When fixing the touch screen in place, fix it using the bottom section such as by fixing it to the LCD display. Fixing the top electrode to the case or housing with double-sided tape, etc. causes stress to be placed on the connection between the top and bottom electrodes, which may cause damage or distortion to the film or malfunctions.
- Some products have an air vent installed to ensure that the inner and outer pressure of the touch screen are the same. Make sure that this is not blocked when installing. Furthermore, ensure that liquids such as water and oil do not enter the product through the air vent or product exterior (connection section between the top and bottom electrodes).
- Avoid any situations where air pressure from a device attached to the touch screen could pass through the air vent and cause the top electrode to swell. Doing so may have a bad effect on the product such as reducing the lifespan of the product. Furthermore, reducing the pressure in the touch screen through the air vent may cause interference fringe or constant input to occur.
- Please note that moisture from condensation, etc. on the tail connection section or edges may result in migration, causing short circuit failure to occur.

Handling precautions

- When unpacking the product, make sure the product is facing in the correct vertical/horizontal orientation. Furthermore, glass edges have not been chamfered and may be sharp. Be sure to wear gloves when handling the products to avoid cuts.
- Do not use a clamp to lift or pull the tail section. Doing so may result in damage to the tail connection section.
- Wear gloves or fingerstalls to prevent the fingerprints or dirt from getting onto the product.
- When holding the product, hold it outside of the range of the visible area.
- To remove dirt from the surface of the product, wipe gently with a soft cloth soaked in ethanol. Do not use anything other than ethanol.
- When storing the product, wrap it in the same packaging as when it was purchased and within the temperature and humidity conditions prescribed in the specifications.
- Do not store the product in an acidic environment or near other corrosive gases.
- Do not store the product in locations where condensation may occur.
- Do not stack products or place other items on the products, as doing so places excess load on the products, which may result in deformation or bending of the products or scratches to the edges of the products.
- The product has a protective film attached. Do not remove this film until immediately before use to prevent the product from becoming scratched, etc. However, storing the product with the protective film attached for prolonged periods may result in the adhesive from the protective film becoming attached to the product.

Precautions for Operation

- Do not operate the product with anything other than your finger or a specialized input pen (commercially available polyacetal pen). In particular, do not use sharp objects such as a ballpoint pen or mechanical pencil. Doing so may cause scratches to the surface, malfunctions and cracked glass.
- The area between the visible area and key area is structurally weak. Do not rub harshly with a pen, etc.

(Continued on next page)

► Operation Instructions

Design Precautions

- The input position of analog type products may become misaligned due to resistance value differences between individual products, or changes to the resistance value due to age deterioration. Be sure to enable calibration using both hardware and software to calibrate the input position.
- When installed onto a display device such as an LCD, noise generated by the display device may cause malfunction. Implement noise countermeasures such as connecting the frame of the display device to ground.
- The contact resistance of the product changes when pressed by a finger or pen. Ensure that data is read when the contact resistance is stable, such as by ignoring data read when the contact resistance is unstable.
- Data becomes broken on the dot spacer of analog type products when used for drawing lines, etc., and must be corrected using software.
- Be sure to evaluate sufficiently when using double-sided tape or adhesive to attach the top electrode to the surface sheet. Distortion, etc. of the top electrode or surface sheet may have an adverse effect on functionality.

Precautions for Use

- Do not use this product for systems that require a particularly high level of reliability, such as safety devices or control systems for atomic power, aviation, medical and on-board devices.
- Products are guaranteed based on the evaluation of product standards within the moisture tolerance and usage temperature range, but are not guaranteed to operate perpetually at this temperature.
- Touch screens have individual differences. Therefore, calibration data from one touch screen should not be applied to other touch screens, and calibration should be implemented for each touch screen.
- If the connector is removed and reconnected from the tail after calibration, perform calibration again.
- The prescribed specifications are a guarantee of product quality on a single touch screen. When using the product, be sure to confirm and evaluate performance when attached to your own products.

Analog Type

1. The product has a two-layer structure consisting of a polyester (PET) film that has an ITO membrane and a sheet of glass, and the total surface of top and bottom electrodes have a uniform resistive film. One electrode draws in the X axis direction and the other in the Y axis direction. When pressure is applied using a finger, etc., changes to the resistance value between X1 to X2 and Y1 to Y2 are read and converted to a digital value.

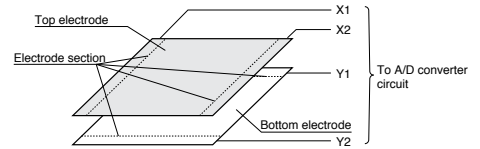

2. In order for the position touched by an input operation to be read, a voltage of 5 V is applied to the top electrode (X1 to X2). At this time, the voltage change in the direction of the arrow is uniform between 0 V to 5 V.

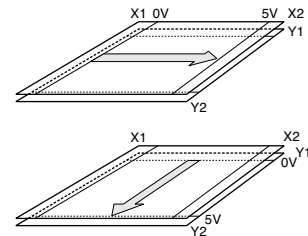

3. Assume that the center of the top electrode is touched. The position where the top electrode is touched comes into contact with the bottom electrode, and a voltage of 2.5 V is output to Y1 (or Y2). The output voltage can be converted to A/D and read as an X coordinate value. In the same way as the X side, the Y coordinate between Y1 and Y2 on the bottom electrode is read, and the point where the X and Y coordinates overlap can be read as the touched position.

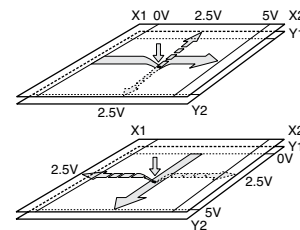

4. The resolution can be made comparatively higher than a digital type, and the degree of freedom in displaying button designs on the display screen also increases. As the normal concept for analog types is point detection as opposed to key numbers, text and drawing input can be achieved using a pen. The vertical and horizontal resolution (detection points) is 1024 when a 10-bit A/D converter is used.

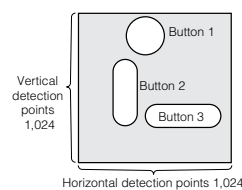

The key areas of each button do not interfere with each other.

Broadening the World of Touch Screens with Precisely Designed Resistive Film from a Specialist in Industrial Switches

NKK's New Touch Screens

As we branched out into touch screens and sheet keyboards, a key question on our minds was how we could take the technology and experience we had amassed as one of the world's top specialist manufacturers of industrial switches and apply these to the latest electronic devices to add value.

The answer to this question lay in each of our products. Our keywords are "global accessibility", "reliability", "innovation" and "speed".

With the technology we have amassed by making industrial switches, we can promise users around the world that the products they buy from us will be ultra-reliable, with quality and performance that exceed their specs.

We are also constantly taking the next innovative step in communication between people and machines...and we do it fast.

As a specialist manufacturer of industrial switches, we have top-notch standards and take pride in what we do.

For those wanting light-touch operation similar to electrostatic capacitance panels
Series TP01 4-Wire Analog

4:3

10.4" 12.1" 15" 19"

Wide

10.6" 12.1" 15.6"

For those wanting multi-touch operation similar to electrostatic capacitance panels
Series TP01 4-Wire Analog

4:3

10.4" 12.1" 15" 19"

Wide

10.6" 12.1" 15.6"

Control Board **IC**

- Control boards and ICs can only be purchased in a set with a touch screen.

For those wanting a steady supply of a tried-and-true product
Series FT Digital

5.7"

NKK Supplies a Wide Range of Touch Screens to Meet the Needs of All Different Customers

For those wanting a highly reliable panel
Series FT 5-Wire/8-Wire Analog

4:3

10.4" 12.1" 15"

Control Board **IC**

- The 8-wire analog type is custom-made. All sizes of the 4-wire type support an 8-wire conversion tail.

For those wanting a wide range of sizes
Series FT 4-Wire Analog

4:3

5.7" 6.5" 8.4" 10.4" 12.1" 15" 19"

Wide

10.6" 12.1" 15.6"

Control Board **IC**

* Specifications presented here are subject to change without notice. Check with our staff for the latest specifications.